

# Stoffkarte

*Fabric card*

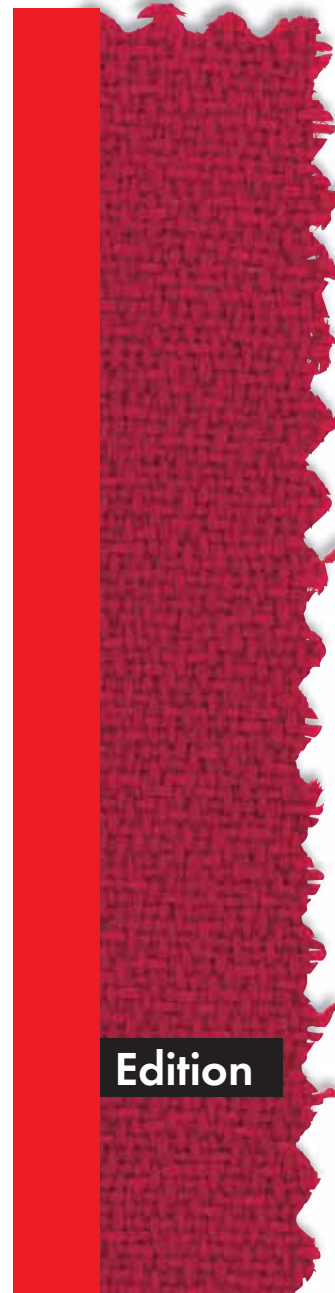

Classic



Edition

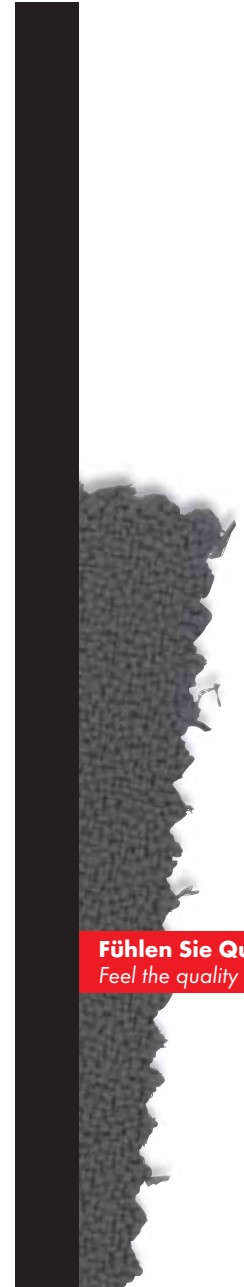

Fühlen Sie Qualität  
Feel the quality

STEIFENSAND 

Vom Sitzen besessen.

## STRUKTURÜBERSICHT / SURVEY OF STRUCTURES

<b>1</b>	<b>Skai</b> Kunstleder/imitation leather
473	grau/grey
	

**Optik Leder, Material strapazierfähig und pflegeleicht, Preis moderat!**

Leather-look, long-wearing and easy-care material, moderate price!

<b>1</b>	<b>Ottawa</b>
309	grün/green
	

**Dezente Farben und Muster halten den Stoff dauerhaft schön.**

Subdued colours and patterns maintain the fabric durably beautiful.

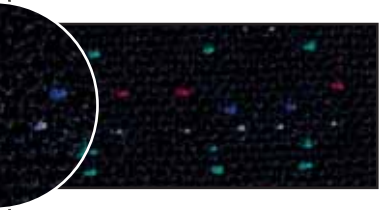
<b>1</b>	<b>Bangkok</b>
512	schwarz/black
	

**Robuste Stoffbeschaffenheit, teilweise mit Musterelementen veredelt.**

Robust fabric quality, optionally beautified by pattern elements.

<b>3</b>	<b>Gaja</b>
200	gelb/yellow
	

**Exklusives Design, ausdrucksstarke Farben für besondere Ansprüche.**

Exclusive design, expressive colours for special requirements.

<b>3</b>	<b>Sydney</b>
324	dunkelrot/dark red
	

**Muss man einfach immer wieder anfassen! Wohlfühlfaktor eins!**

You always have to touch it! Perfect sense of well-being!

<b>3</b>	<b>Dakar</b>
237	blau/blue
	

**Schmutz abweisend, die Blicke anziehend - dank veredelter Oberfläche.**

Antisoiling, eye-catching fabric - thanks to an excellent surface.

## STRUKTURÜBERSICHT / SURVEY OF STRUCTURES

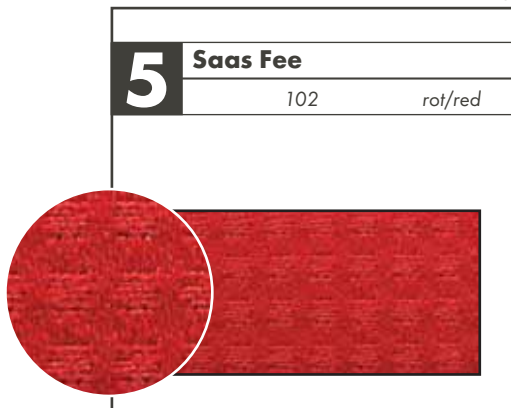

**Ausdrucksstark: Webart und Farbpalette machen diesen Stoff zum Klassiker.**

Expressive: The kind of weaving and the colour range turn this fabric into a classic!

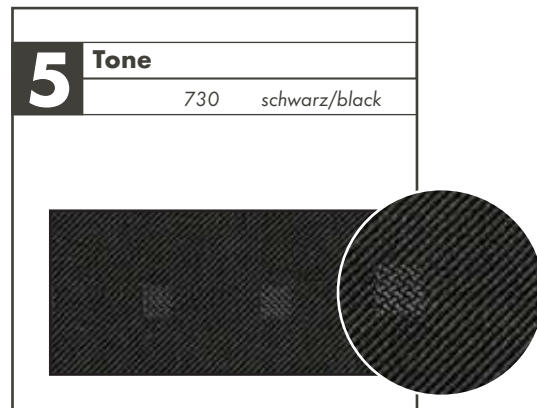

**Unterstreicht stilvolles Interieur: feines Gewebe mit eleganter Musterung.**

Emphasizes the stylish interior: Fine material with an elegant pattern.

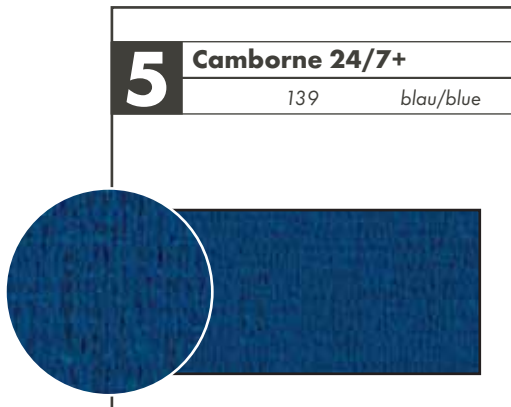

**Hochstrapazierfähiges Spezialgewebe für den 24-Stunden Einsatz.**

Long-wearing special material for 24 hour use in constant activity.

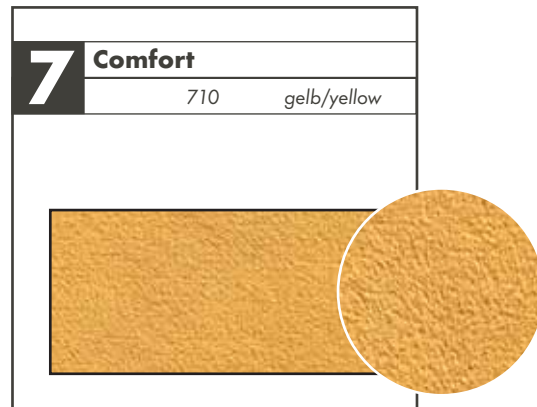

**100 % Gefühl und leuchtende Farben – Akzente setzen und wohlfühlen!**

100 % feeling and bright colours - set new trends and feel good!



**Echtes Leder: Luxus für alle Sinne, vereint mit zeitloser Optik.**

Genuine leather: luxury for the senses, combined with timeless looking.



**Funktion pur. Widerstands- und leitfähiges Material in dezenter Optik.**

Pure function. Robust, conductive, subdued looking material.

Geringfügige Farbabweichungen zum Original-Material sind drucktechnisch bedingt.  
Slight colour variations cannot be avoided.

**1****Stoffgruppe 1 - Skai Kunstleder****Fabric group 1 - Skai Imitation leather****404 weiß/white****473 grau/grey****Kunstleder/Imitation leather**Gewicht je m<sup>2</sup>/Weight per m<sup>2</sup> **580 g**Breite/Width **137 cm**Lichtechtheit/Colour fastness **4**Reibechtheit Trocken/Nass/  
Colour fastness to rubbing dry/wet **5 / Benzin 5**Feuersicherung nach/  
Flammability **• DIN 53438****Wissenswertes über Skai Kunstleder:**

- Reiß- und weiterreißfest • Urinbeständig
- Desinfektionsmittelbeständig (Biguamed) • Blutbeständig
- Speichel- und schweißecht gemäß DIN 53160

**Useful information about skai imitation leather:**

- Resistant to tearing and further tearing • urine proof
- disinfectant proof (biguamed) • blood proof
- fast to salivary and perspiration as per DIN 53160

**471 braun/brown****472 schwarz/black**

Bedingt geeignet für DISCUS-, ENERGO-, SERVO-, LOC 401-, YOGA-, COCKPIT- und MITO-Modelle.

Only partially suitable for DISCUS, ENERGO, SERVO, LOC 401, YOGA, COCKPIT and MITO chairs.

**1****Stoffgruppe 1 - Bangkok****Fabric group 1 - Bangkok****501 rot/red****502 rot/red****100 % Dralon/100 % Dralon**Gewicht in lfdm/  
Weight per running meter **500 g**Breite/Width **135 cm**Lichtechtheit/Colour fastness **5 - 7**Reibechtheit Trocken/Nass/  
Colour fastness to rubbing dry/wet **5 / Benzin 5**Scheuerfestigkeit in  
Scheuertouren (nach Martindale)/  
Abrasion resistance  
(rubs Martindale) **30.000****509 grün/green****510 grün/green****505 grau/grey****506 grau/grey**

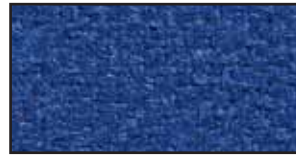
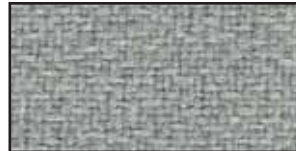
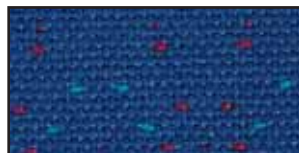
**1****Stoffgruppe 1 - Ottawa****Fabric group 1 - Ottawa****304 royalblau/royal blue****310 nachtblau/dark blue****100 % Polyolefin/100 % Polyolefin**Gewicht in lfdm/  
Weight per running meter **450 g**Breite/Width **140 cm**Lichtechtheit/Colour fastness **6**Reibeechtheit Trocken/Nass/  
Colour fastness to rubbing dry/wet **3 - 4 / 3**Scheuerfestigkeit in  
Scheuertouren (nach Martindale)/  
Abrasion resistance  
(rubs Martindale) **50.000**Feuersicherung nach/  
Flammability **• EN 102-1 - 1994  
Zigarettestest/  
Cigarette test****312 grau/grey****311 schwarz/black****309 grün/green****308 rot/red****507 weinrot/wine red****508 weinrot/wine red****503 blau/blue****504 blau/blue****511 schwarz/black****512 schwarz/black**

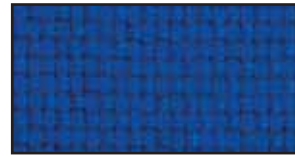
**3****Stoffgruppe 3 - Dakar****Fabric group 3 - Dakar****237 blau/blue****231 braun/brown****100 % Polefin/100 % Polefin**Gewicht in lfdm/  
Weight per running meter **510 g**Breite/Width **145 cm**Lichtechtheit/Colour fastness **7**Reibeechtheit Trocken/Nass/  
Colour fastness to rubbing dry/wet **5**Scheuerfestigkeit in  
Scheuertouren (nach Martindale)/  
Abrasion resistance  
(rubs Martindale) **150.000****238 schwarz/black****233 rot/red****234 hellrot/light red****3****Stoffgruppe 3 - Gaja****Fabric group 3 - Gaja****200 gelb/yellow****100 % Kammgarnwolle - reine New-Zealand-Wolle, naturweiß, ungebleicht/  
100 % worsted wool - pure New Zealand wool, natural white, unbleached**Gewicht in lfdm/  
Weight per running meter **560 g**Breite/Width **150 cm**Lichtechtheit/Colour fastness **4 - 6**Reibeechtheit Trocken/Nass/  
Colour fastness to rubbing dry/wet **4 - 5 / 4 - 5**Scheuerfestigkeit in  
Scheuertouren (nach Martindale)/  
Abrasion resistance  
(rubs Martindale) **50.000****204 grün/green****203 dunkelrot/dark red**Feuersicherung nach  
Flammability **• DIN 54342, 1 + 2** **• EN 1021, 1 + 2**  
**• BS 5852, 0 + 1** **• DIN 4102 B2**  
**• NFP 92503: M2**

**Besondere Eigenschaften des Stoffes Dakar,  
die ihn für den Einsatz in Büro und Industrie auszeichnen:**



- 150.000 Scheuertouren
- schmutzabweisend • allergiehemmend • antibakteriell
- säure- und alkalibeständig • hohe Knitterfestigkeit • heiss verschweisbar
- keine Pillingbildung • kein Schimmelbefall
- hohe Reisskraft und Reibefestigkeit
- geringe elektrostatische Aufladung
- bei Verbrennung bilden sich keine toxischen Gase
- beständig gegen Trichloroäthylen, Perchloraethylen und Azeton
- es bildet sich keine elektrostatische Aufladung, somit werden keine Staubpartikel aus der Luft angezogen
- Klassifikation des Brennverhaltens - Klasse 1 M1 (nicht entflammbar)

**Special characteristics of the fabric Dakar, by which its application in the  
office and industry is distinguished:**



- 150.000 rubs
- antisoiling • anti-allergic • anti-bacterial
- acid and alkali proof • high resistance to crease • thermo-welding properties
- anti-pilling • mould resistant
- high resistance to tearing and friction
- low antistatic charge
- no toxic gases at forced combustion
- resistant to trichloroethylene, perchloroethylene and acetone
- avoids electrostatic charge and consequently does not attract dust from the air
- classification of inflammability - class 1 M1 (not inflammable)

Andere Farbnuancen auf Anfrage verfügbar. Other colours available on request.

**214 aqua/aqua**



**207 royalblau/royal blue**



**211 nachtblau/dark blue**

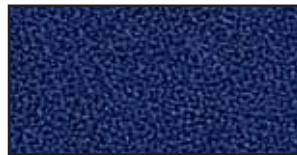

**208 schwarz/black**

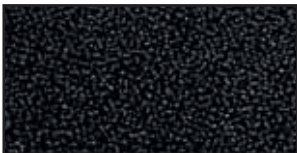

**206 türkis/turquoise**

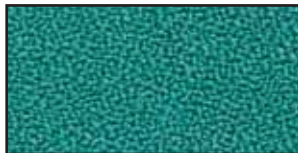

**202 rot/red**



**212 terrakotta/terra cotta**



**213 silbergrau/silver grey**



**209 grau/grey**



Weitere Farbnuancen auf Anfrage verfügbar. Bitte fragen Sie auch nach unserer Antistatik-Variante.

Other colours available on request. Please also ask for our antistatic variant.

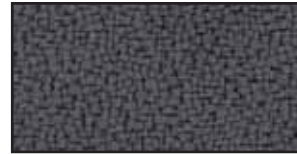
**3****Stoffgruppe 3 - Sydney****Fabric group 3 - Sydney****327 rot/red****324 dunkelrot/dark red****100% Trevira CS/  
100% Trevira CS**Gewicht in lfdm/  
Weight per running meter **440 g**Breite/Width **140 cm**Lichtechtheit/Colour fastness **5-6**Reibeechtheit Trocken/Nass/  
Colour fastness to rubbing dry/wet **5 / 4-5**Scheuerfestigkeit in  
Scheuertouren (nach Martindale)/  
Abrasion resistance  
(rubs Martindale): **100.000**Feuersicherung nach/  
Flammability **• DIN 4102 B1****328 grau/grey****323 nachtblau/dark blue****321 blau/blue****320 schwarz/black**

Andere Farbnuancen auf Anfrage verfügbar. Other colours available on request.

**5****Stoffgruppe 5 - Saas Fee****Fabric group 5 - Saas Fee****103 gelb/yellow****105 schwarz/black****92 % Wolle, 8 % Polyamid/  
92 % wool, 8 % polyamide**Gewicht in lfdm/  
Weight per running meter **555 g**Breite/Width **135 cm**Lichtechtheit/Colour fastness **5 - 7**Reibeechtheit Trocken/Nass/  
Colour fastness to rubbing dry/wet **4 / 4**Scheuerfestigkeit in  
Scheuertouren (nach Martindale)/  
Abrasion resistance  
(rubs Martindale) **45.000**Feuersicherung nach/  
Flammability **• EN 1021, 1 + 2  
• DIN 54342, 1 + 2  
• BS 5852, 1 + 2  
• ISO 8191, 1 + 2****104 petrol/petrol****102 rot/red**

Andere Farbnuancen auf Anfrage verfügbar. Other colours available on request.

**5****Stoffgruppe 5 - Tone****Fabric group 5 - Tone****735 rost/russet****734 rot/red****100 % Kammgarnwolle/  
100 % worsted wool**Gewicht in lfdm/  
Weight per running meter**500 g**

Breite/Width

**150 cm**

Lichtechtheit/Colour fastness

**5 - 6**Reibeechtheit Trocken/Nass/  
Colour fastness to rubbing dry/wet**4 / 5**Scheuerfestigkeit in  
Scheuertouren (nach Martindale)/  
Abrasion resistance  
(rubs Martindale)**50.000**Feuersicherung nach/  
Flammability

- EN 1021, 1 + 2
- BS 5852, 1 + 2
- DIN 54342, 1 + 2
- NFP 92503: M2

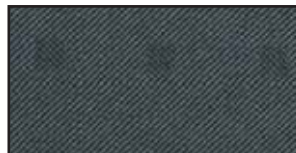
**733 grün/green****731 blau/blue****732 grau/grey****730 schwarz/black**

Andere Farbnuancen auf Anfrage verfügbar. Other colours available on request.

**107 anthrazit/anthracite****106 braun/brown****101 nachtblau/dark blue****100 royalblau/royal blue**

**5****Stoffgruppe 5 - Camborne 24/7+****Fabric group 5 - Camborne 24/7+****139 blau/blue****142 nachtblau/dark blue**

**50 % Polyamide, 33 % reine Schurwolle, 10 % Visil, 7 % Viskose/ 50 % polyamide, 33 % pure new wool, 10 % visil, 7 % viscose**

Gewicht in lfdm/  
Weight per running meter **610 g**

Lichtechtheit/Colour fastness **6**

Reibeechtheit Trocken/Nass/  
Colour fastness to rubbing dry/wet **4**

Scheuerfestigkeit in  
Scheuertouren (nach Martindale)/  
Abrasion resistance  
(rubs Martindale) **500.000**

Feuersicherung nach/  
Flammability **• EN 1021, 1 + 2  
• BS 7176: 1995  
• BS 5852: 1990**

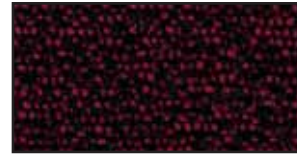
**140 rot/red****141 schwarz/black**

- 10 Jahre Garantie gegen Durchscheuern
- Hochstrapazierfähiges Spezialgewebe entwickelt für den 24-Stunden Rund-um-die-Uhr Einsatz
- 10 years guarantee against abrasion
- Long-wearing special material designed for 24 hour use, seven days a week in constant activity

Weitere Farbnuancen auf Anfrage verfügbar. Other colours available on request.

**L****Leder****Leather****771 dunkelbraun/ dark brown****775 burgund/burgundy****Leder, Anilinleder**

Beim Naturprodukt Leder sind Struktur- oder Farbunterschiede unvermeidbar. Naturmerkmale wie Masenfalten, Insektenstiche, Hautverletzungen etc. bleiben sichtbar. Für Farbunterschiede kann keine Garantie übernommen werden.

Bedingt geeignet für DISCUS-, STANDARD-/PROFI und INDUSTRY-Modelle.

**Leather, aniline leather**

With leather being a natural product, colour and structure variations cannot be avoided. Marks and small cracks as well as folds are typical of this material and consequently give it a certain originality. No guarantee for colour variations. Partially suitable for DISCUS, STANDARD/PROFI and INDUSTRY chairs.

**772 schwarz/black****776 blau/blue****773 grau/grey****777 rot/red**

**7****Stoffgruppe 7 - Comfort****Fabric group 7 - Comfort****88 % Polyester, 12 % Polyurethan/  
88 % Polyester, 12 % Polyurethan**Gewicht in lfdm/  
Weight per running meter **385 g**Breite/Width **140 cm**Lichtechtheit/Colour fastness **5**Reibeechtheit Trocken/Nass/  
Colour fastness to rubbing dry/wet **4 - 5 / 4 - 5**Scheuerfestigkeit in  
Scheuertouren (nach Martindale)/  
Abrasion resistance  
(rubs Martindale) **100.000**Feuersicherung nach/  
Flammability 

- DIN 54342, 1 + 2
- EN 1021, 1 + 2
- BS 5852, 0 + 1
- DIN 4102 B2
- NFP 92503: M2

**710 gelb/yellow****711 apricot/apricot****712 rot/red****718 royalblau/royal blue****713 blau/blue****720 schwarz/black**Bedingt geeignet für DISCUS-Modelle. Weitere Farbnuancen auf Anfrage verfügbar. *Partially suitable for DISCUS chairs. Other colours available on request.***10 Jahre Garantie gegen Durchscheuern. 10 years guarantee against abrasion.****Antistatik-Stoff****Antistatic fabric****40 % Wolle 1 % BASF Resistat®, 59 % Viskose/  
40 % wool, 1 % BASF Resistat®, 59 % viscose**Gewicht in lfdm/  
Weight per running meter **590 g**Breite/Width **140 cm**Lichtechtheit/Colour fastness **5**Reibeechtheit Trocken/Nass/  
Colour fastness to rubbing dry/wet **3 / 3 - 4**Scheuerfestigkeit in  
Scheuertouren (nach Martindale)/  
Abrasion resistance  
(rubs Martindale) **60.000**Feuersicherung nach/  
Flammability 

- EN 1021, 1 + 2

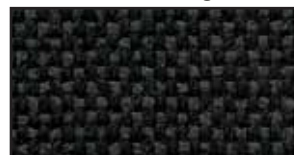
**820 anthrazit/anthracite****822 grün/green****821 schwarz/black****828 braun-meliert/  
brown melange**

[www.original-steifensand.de](http://www.original-steifensand.de)



Firmensitz von F.-Martin Steifensand ist Freystadt. Dort läuft die gesamte Produktion. Auch Sonderwünsche lassen sich so schnell und flexibel realisieren.

### **Produktion / production**

Headquarters of F.-Martin Steifensand in Freystadt with the complete production. Special demands can be realised quickly and in a flexible way.

Ein Blick in die Entwicklungsabteilung von STEIFENSAND®: Nur Prototypen, die den Belastungstest bestehen, gehen in Produktion.

### **Entwicklung / development**

A look at the development department of STEIFENSAND®: Only prototypes, which pass the load test, are put into production.



Nach einer ausführlichen Sicht- und Stabilitätsprüfung rollen die STEIFENSAND®s in den Versand.

### **Qualität / quality**

After a detailed visual check and stability test the STEIFENSAND® chairs roll into the despatch department.

In Sachen Sitzen immer für Sie da: Das kompetente Service-Team von STEIFENSAND®.

### **Service / customer service**

The competent STEIFENSAND® service team is pleased to be at your disposal when seating is concerned.



**Ihr Fachhandelspartner/Your dealer specialist**

**Weitere Informationen zu unseren Produkten erhalten Sie bei / For more Information to our products ask:**  
F.-Martin Steifensand Büromöbel GmbH | Thundorfer Strasse 11 | 92342 Freystadt/Rettelloh  
Telefon +49 (0) 9179/96 55 - 0 | Telefax +49 (0) 9179/96 55 - 44 | [mail@original-steifensand.de](mailto:mail@original-steifensand.de)